

# Mast Section Comparison (AUS) Paper Tiger Catamarans

Note: Comparison of the most common mast sections used by Paper Tiger Catamarans in Australia over the last 20 years.



Paper Tiger Catamaran  
**GUIDES**

DRN: David Stumbles	CHKD: ?	REV. No: 2	REV. DATE: 29-05-2009
DATE: 19-02-2009	SCALE: NTS	© Paper Tiger Catamaran International Association (PTCIA)	

For Paper Tiger Catamaran assistance & suggestions for these Guides contact PTCIA Secretary David Stumbles on +61 (0) 400 476 449 or [ptcia@papertigercatamaran.org](mailto:ptcia@papertigercatamaran.org) or visit [www.papertigercatamaran.org](http://www.papertigercatamaran.org) File: Guide – Mast Section Comparison (AUS)

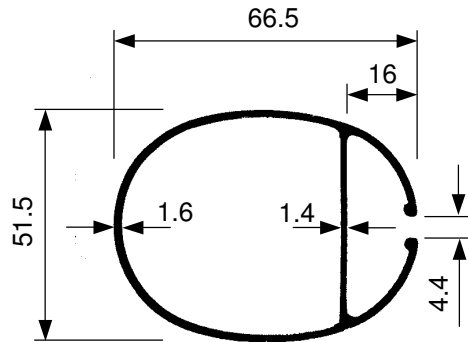

ALCAN

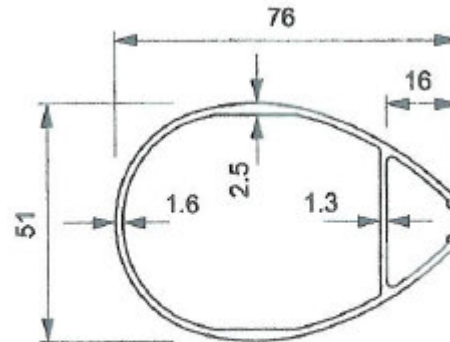

AUSTRALIAN  
369.5 sq.mm

## Alcan (also Comalco or Capral)

Manufactured in Australia. Still available. More flexible than the others shown here so doesn't suit latest sails. Popular for booms.

## Australian

Manufactured in Australia. No longer produced. Section originally commissioned by Neil Williams (Vic). Dye broke in manufacture and was not repaired.

## American

Manufactured in the USA. Imported to Australia by Goodall Yacht Sails (Vic). Still available. Two variations shown.

## PT Star

Manufactured in China. Imported to Australia by Garry Williams (NSW). First run available February 2009.

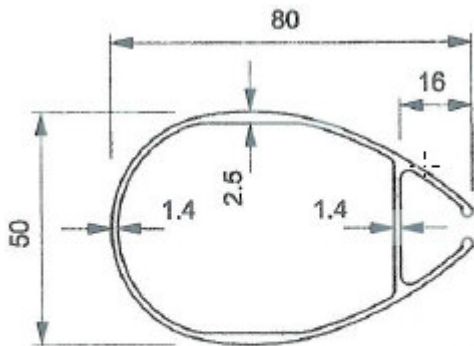

AMERICAN (Light)  
354.6 sq.mm

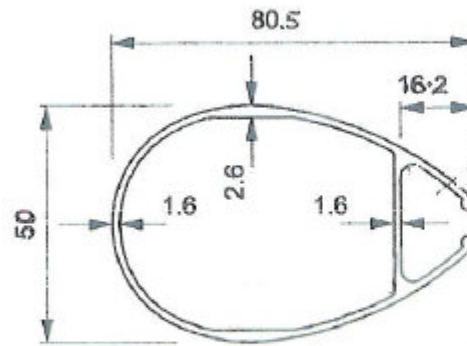

AMERICAN (Heavy)  
400.7 sq.mm

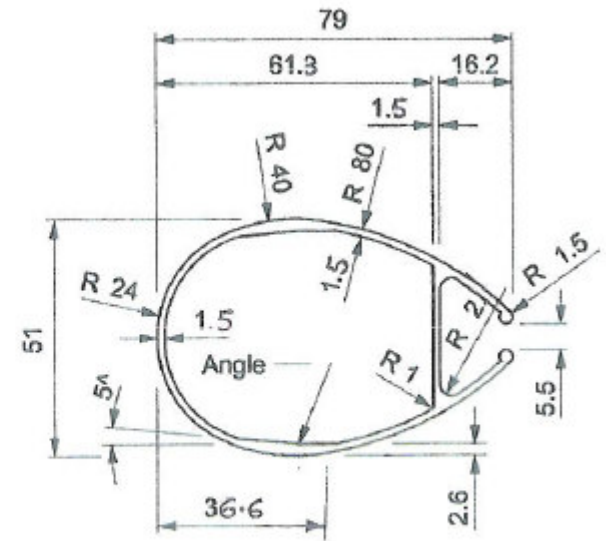

P.T. STAR  
375.86 sq.mm